



安裝手冊

STAGE3 607C
STAGE3 607CF
STAGE3 427
STAGE3 427F
STAGE3 527

STAGE3 527F
STAGE3 627
STAGE3 627F
STAGE3 637F
STAGE3 6427

STAGE3 8627
STAGE3 9637
STAGE3 9637F

STAGE3 607C

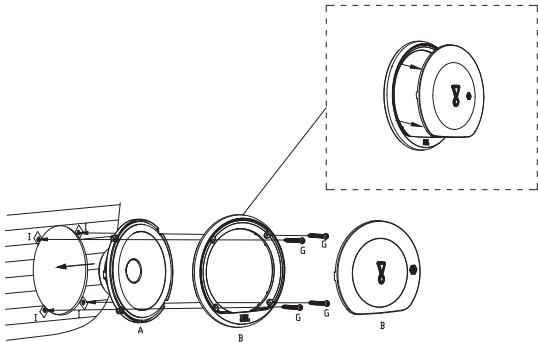

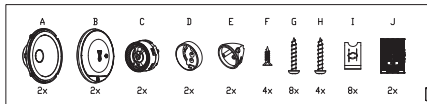
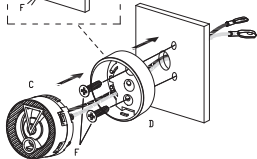
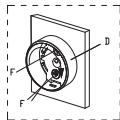
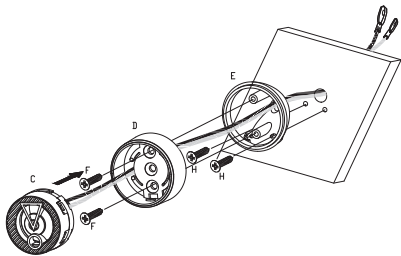

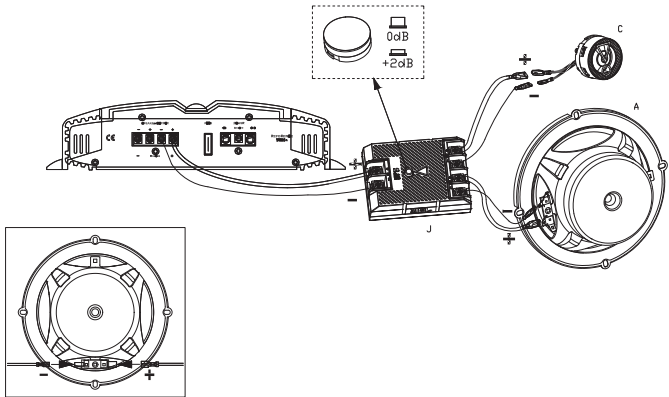

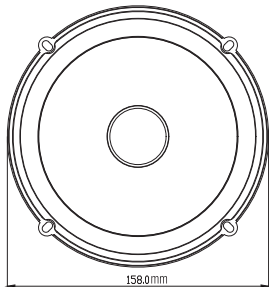
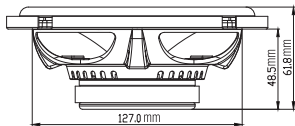
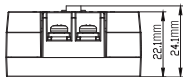
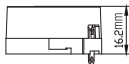
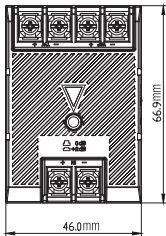

規格

- 類型: 6-1/2" (165mm) 雙向元件系統
汽車喇叭
- 功率容量: 50W RMS, 250W 峰值
- 靈敏度 (2.83 伏特/米): 92dB
- 頻率響應: 55Hz – 20kHz
- 阻抗: 3ohms

TS 參數

- BL (Tm): 3.316
- DCR (ohms): 2.45
- Mms (g): 14.017
- Sd (cm²): 138.93
- Cms (μm/N): 0.316
- Vas (l): 8.6375
- Fs (Hz): 75.6
- Qes: 1.482
- Qms: 11.842
- Qts: 1.317
- Crossover Point: 5kHz

STAGE3 607CF

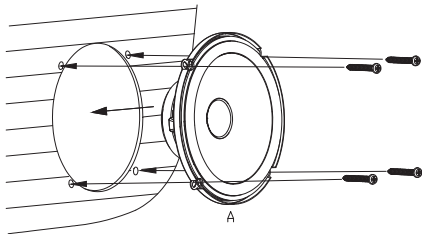

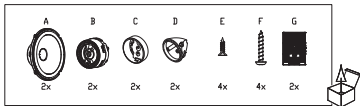
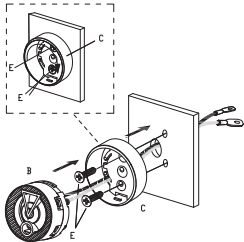
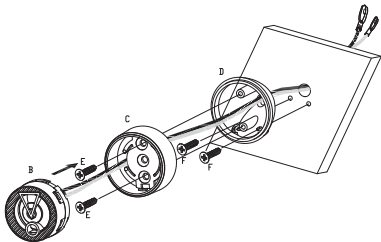

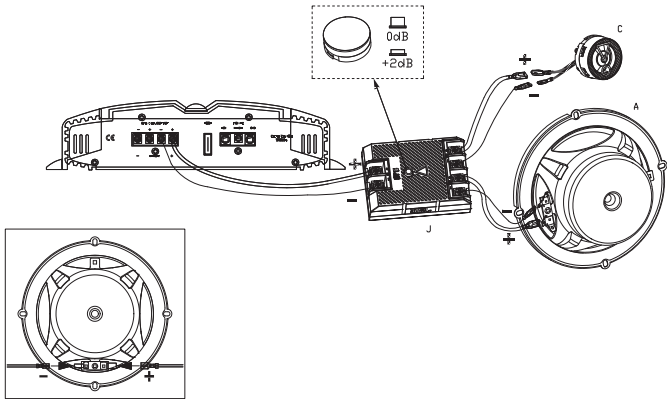

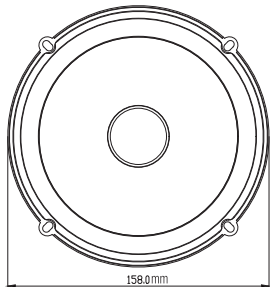
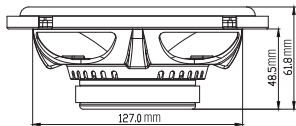
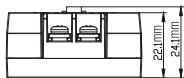
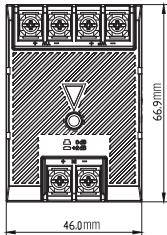

規格

- 類型: 6-1/2" (165mm) 適用於原廠升級的雙向元件系統汽車喇叭, 無格柵
- 功率容量: 50W RMS, 250W 峰值
- 靈敏度 (2.83 伏特/米): 92dB
- 頻率響應: 55Hz – 20kHz
- 阻抗: 3ohms

TS 參數

- BL (Tm): 3.316
- DCR (ohms): 2.45
- Mms (g): 14.017
- Sd (cm²): 138.93
- Cms (µm/N): 0.316
- Vas (l): 8.6375
- Fs (Hz): 75.6
- Qes: 1.482
- Qms: 11.842
- Qts: 1.317
- Crossover Point: 5kHz

STAGE3 427

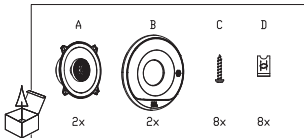
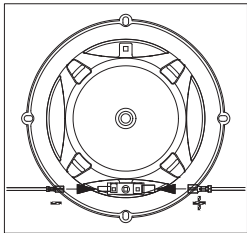
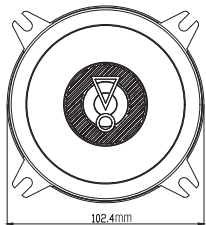
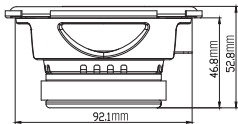

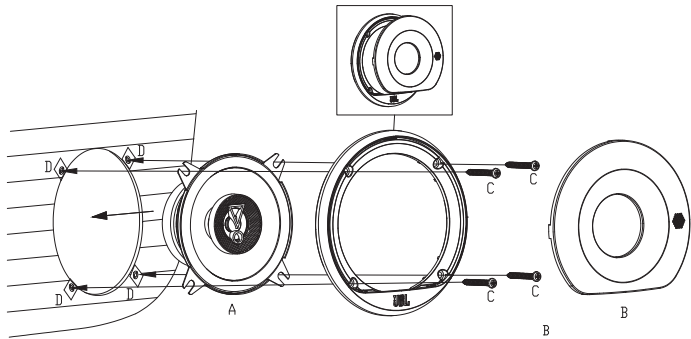

規格

- 類型: 4" (100mm) 雙向同軸汽車喇叭
- 功率容量: 30W RMS, 150W 峰值
- 靈敏度 (2.83 伏特/米): 90dB
- 頻率響應: 75Hz – 20kHz
- 阻抗: 3ohms

TS 參數

- BL (Tm): 2.467
- DCR (ohms): 2.74
- Mms (g): 5.501
- Sd (cm²): 63.62
- Cms (μm/N): 0.387
- Vas (l): 2.2146
- Fs (Hz): 109.1
- Qes: 1.698
- Qms: 12.973
- Qts: 1.501
- Crossover Point: 7kHz

STAGE3 427F

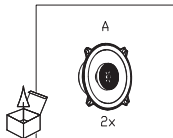
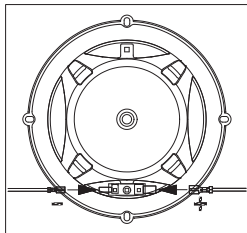
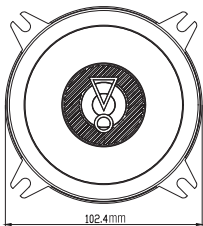
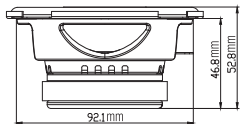

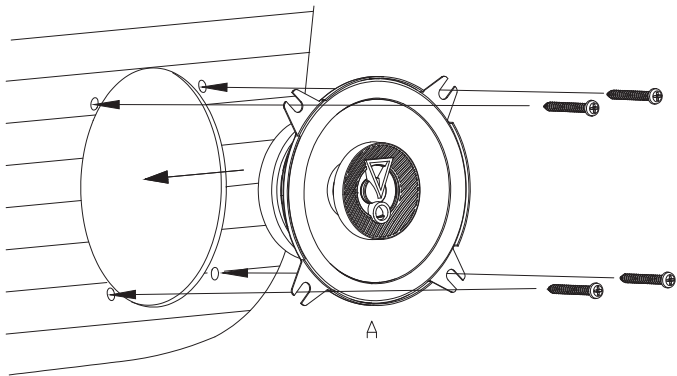

規格

- 類型:4" (100mm) 適用於原廠升級的雙向同軸汽車喇叭, 無格柵
- 功率容量:30W RMS, 150W 峰值
- 靈敏度 (2.83 伏特/米) :90dB
- 頻率響應:75Hz – 20kHz
- 阻抗:3ohms

TS 參數

- BL (Tm): 2.467
- DCR (ohms): 2.74
- Mms (g): 5.501
- Sd (cm²): 63.62
- Cms (μm/N): 0.387
- Vas (l): 2.2146
- Fs (Hz): 109.1
- Qes: 1.698
- Qms: 12.973
- Qts: 1.501
- Crossover Point: 7kHz

STAGE3 527

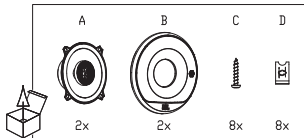
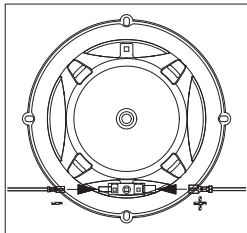
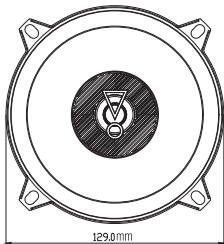
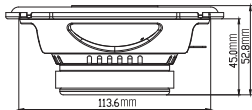

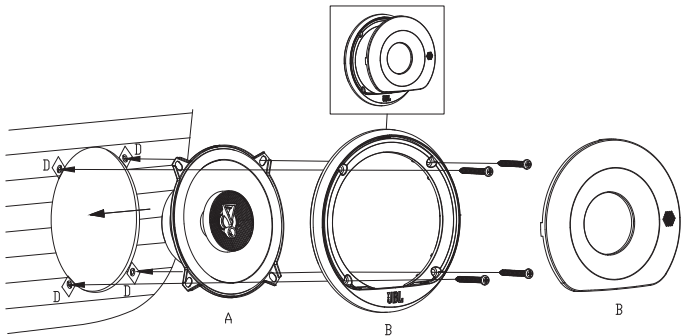

規格

- 類型: 5-1/4" (130mm) 雙向同軸汽車喇叭
- 功率容量: 40W RMS, 200W 峰值
- 靈敏度 (2.83 伏特/米): 91dB
- 頻率響應: 75Hz – 20kHz
- 阻抗: 3ohms

TS 參數

- BL (Tm): 3.148
- DCR (ohms): 2.61
- Mms (g): 9.81
- Sd (cm²): 102.07
- Cms (μm/N): 0.281
- Vas (l): 4.1374
- Fs (Hz): 95.9
- Qes: 1.555
- Qms: 13.546
- Qts: 1.395
- Crossover Point: 6kHz

STAGE3 527F

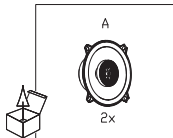
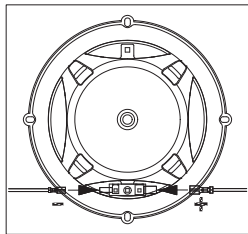
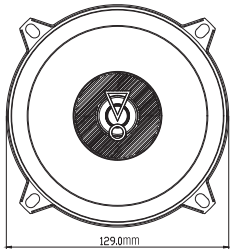
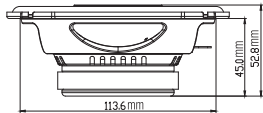

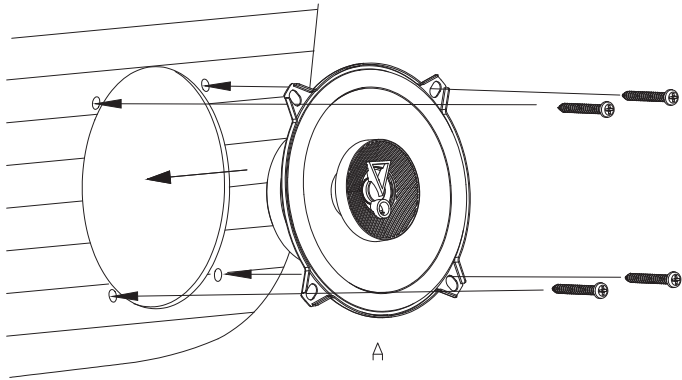

規格

- 類型: 5-1/4" (130mm) 適用於原廠升級的雙向同軸汽車喇叭, 無格柵
- 功率容量: 40W RMS, 200W 峰值
- 靈敏度 (2.83 伏特/米): 91dB
- 頻率響應: 75Hz – 20kHz
- 阻抗: 3ohms

TS 參數

- BL (Tm): 3.148
- DCR (ohms): 2.61
- Mms (g): 9.81
- Sd (cm²): 102.07
- Cms (μm/N): 0.281
- Vas (l): 4.1374
- Fs (Hz): 95.9
- Qes: 1.555
- Qms: 13.546
- Qts: 1.395
- Crossover Point: 6kHz

STAGE3 627

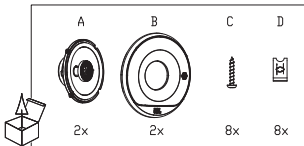
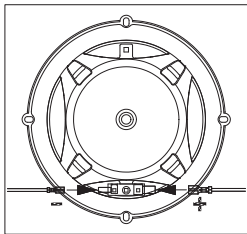
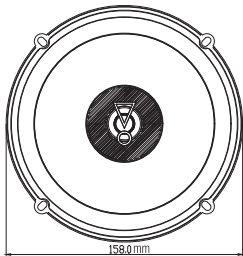
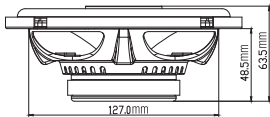

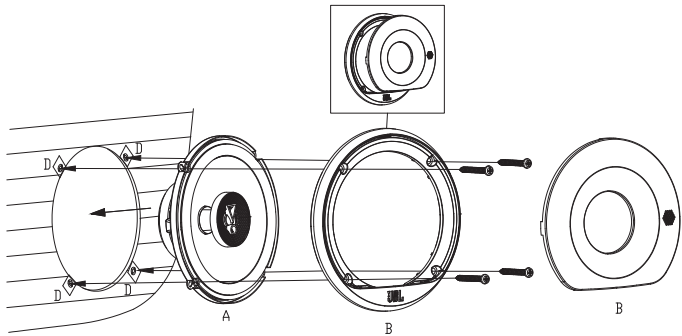

規格

- 類型: 6-1/2" (160mm) 雙向同軸汽車喇叭
- 功率容量: 45W RMS, 225W 峰值
- 靈敏度 (2.83 伏特/米): 92dB
- 頻率響應: 55Hz – 20kHz
- 阻抗: 3ohms

TS 參數

- BL (Tm): 3.347
- DCR (ohms): 2.43
- Mms (g): 13.661
- Sd (cm²): 138.93
- Cms (µm/N): 0.339
- Vas (l): 9.2635
- Fs (Hz): 73.9
- Qes: 1.377
- Qms: 13.148
- Qts: 1.246
- Crossover Point: 5kHz

STAGE3 627F

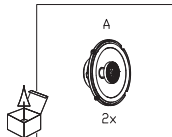
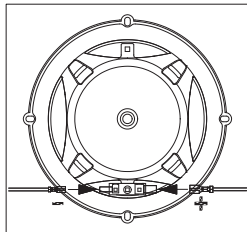
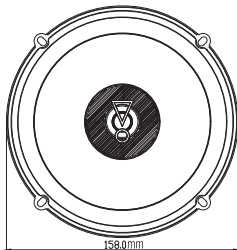
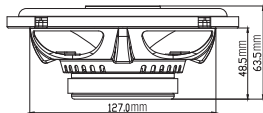

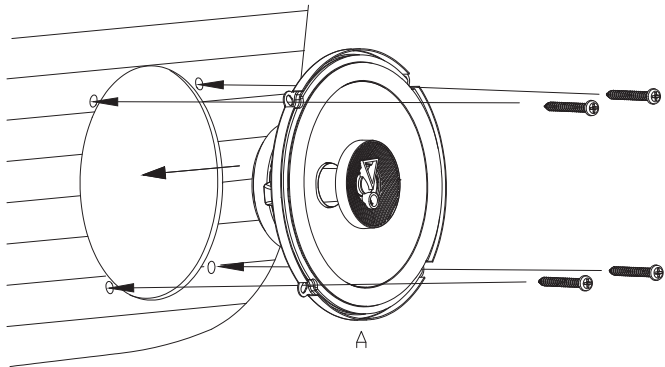

規格

- 類型:6-1/2" (160mm) 適用於原廠升級的雙向同軸汽車喇叭, 無格柵
- 功率容量:45W RMS, 225W 峰值
- 靈敏度 (2.83 伏特/米) :92dB
- 頻率響應:55Hz – 20kHz
- 阻抗:3ohms

TS 參數

- BL (Tm): 3.347
- DCR (ohms): 2.43
- Mms (g): 13.661
- Sd (cm²): 138.93
- Cms (µm/N): 0.339
- Vas (l): 9.2635
- Fs (Hz): 73.9
- Qes: 1.377
- Qms: 13.148
- Qts: 1.246
- Crossover Point: 5kHz

STAGE3 637F

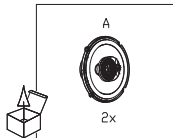
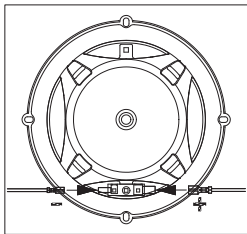
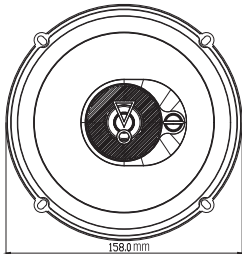
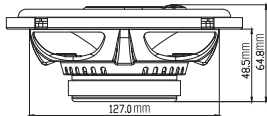

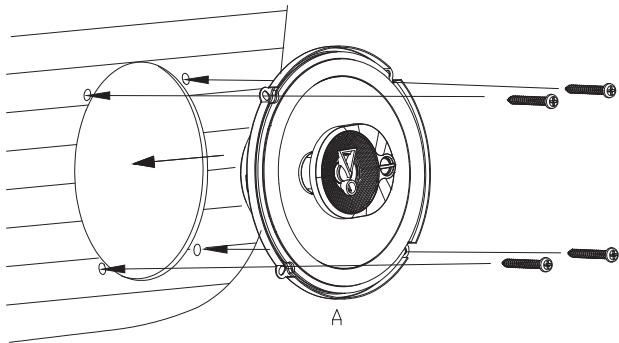

規格

- 類型:6-1/2"(165mm) 適用於原廠升級的三向汽車喇叭,無格柵
- 功率容量:45W RMS, 225W 峰值
- 靈敏度 (2.83 伏特/米):92dB
- 頻率響應:55Hz – 20kHz
- 阻抗:3ohms

TS 參數

- BL (Tm): 3.347
- DCR (ohms): 2.43
- Mms (g): 13.661
- Sd (cm²): 138.93
- Cms (µm/N): 0.339
- Vas (l): 9.2635
- Fs (Hz): 73.9
- Qes: 1.377
- Qms: 13.148
- Qts: 1.246
- Crossover Point: 5kHz

STAGE3 6427

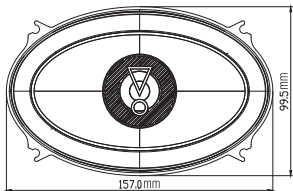
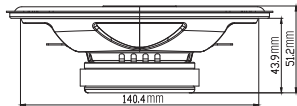

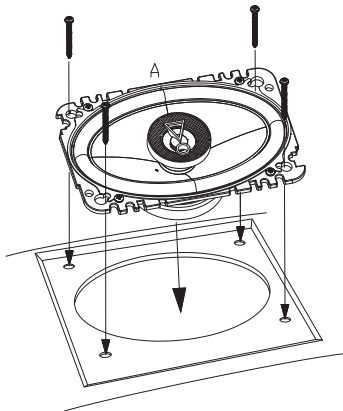
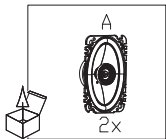
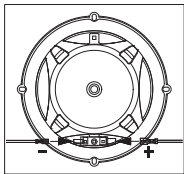

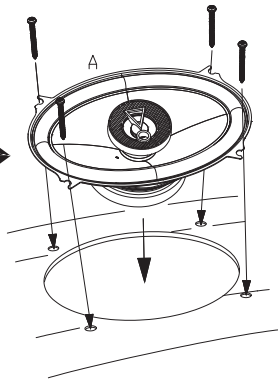
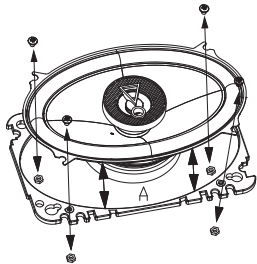

規格

- 類型: 4" x 6" (100mm x 152mm) 雙向同軸汽車喇叭
- 功率容量: 35W RMS, 175W 峰值
- 靈敏度 (2.83 伏特/米): 91dB
- 頻率響應: 75Hz – 20kHz
- 阻抗: 3ohms

TS 參數

- BL (Tm): 3.146
- DCR (ohms): 2.36
- Mms (g): 8.151
- Sd (cm²): 86.59
- Cms (μm/N): 0.272
- Vas (l): 2.884
- Fs (Hz): 106.9
- Qes: 1.307
- Qms: 13.178
- Qts: 1.189
- Crossover Point: 6kHz

STAGE3 8627

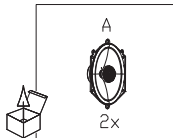
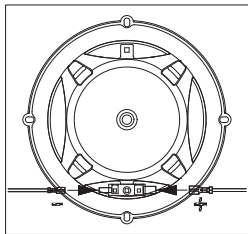
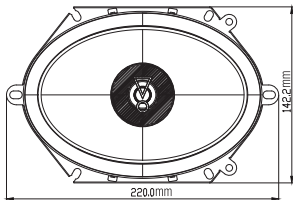
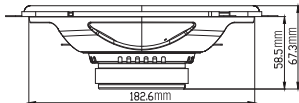

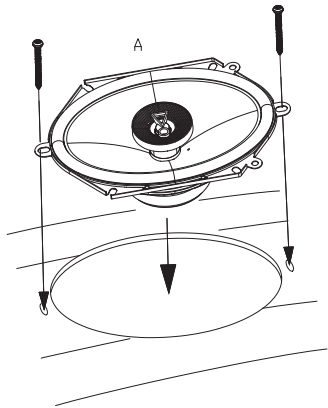
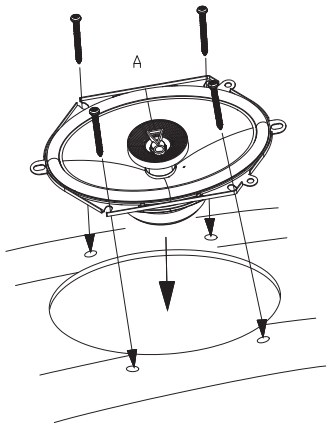

規格

- 類型: 6" x 8" (152mm x 203mm) 雙向同軸汽車喇叭
- 功率容量: 50W RMS, 250W 峰值
- 靈敏度 (2.83 伏特/米): 93dB
- 頻率響應: 65Hz – 20kHz
- 阻抗: 3ohms

TS 參數

- BL (Tm): 3.736
- DCR (ohms): 2.63
- Mms (g): 17.369
- Sd (cm²): 176.71
- Cms (µm/N): 0.396
- Vas (l): 7.7316
- Fs (Hz): 60.7
- Qes: 1.25
- Qms: 11.955
- Qts: 1.132
- Crossover Point: 6kHz

STAGE3 9637

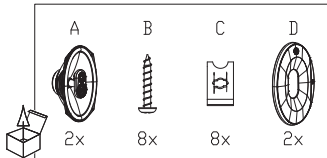
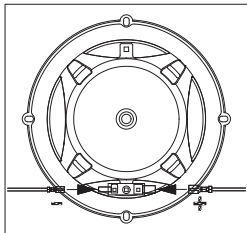
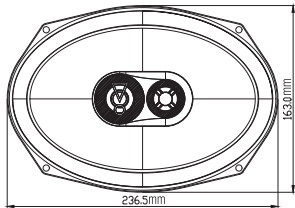
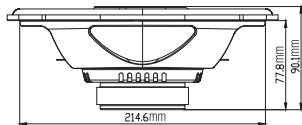

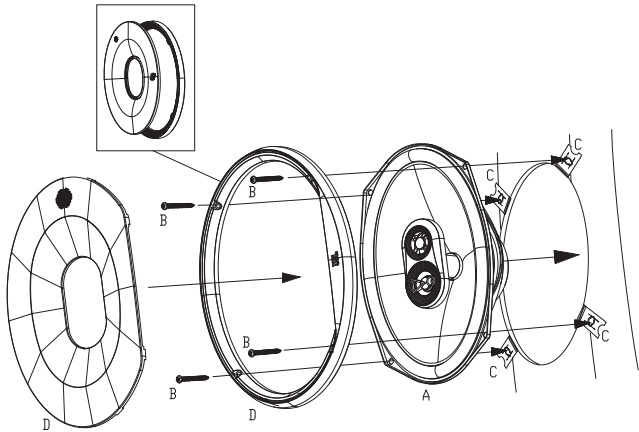

規格

- 類型: 6" x 9" (152mm x 230mm) 三向汽車喇叭
- 功率容量: 75W RMS, 375W 峰值
- 靈敏度 (2.83 伏特/米): 93dB
- 頻率響應: 50Hz – 20kHz
- 阻抗: 3ohms

TS 參數

- BL (Tm): 3.533
- DCR (ohms): 2.34
- Mms (g): 22.973
- Sd (cm²): 237.79
- Cms (μm/N): 0.404
- Vas (l): 32.3563
- Fs (Hz): 52.2
- Qes: 1.413
- Qms: 13.661
- Qts: 1.281
- Crossover Point: 5kHz

STAGE3 9637F

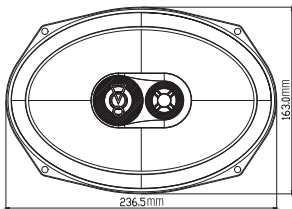
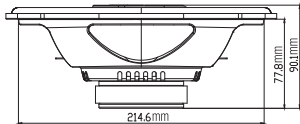

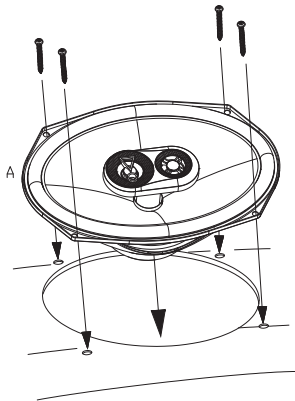
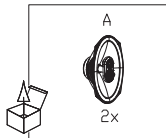
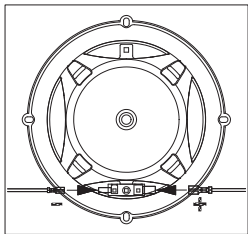

規格

- 類型: 6"x9"(152mmx230mm) 適用於原廠升級的三向汽車喇叭, 無格柵
- 功率容量: 75W RMS, 375W 峰值
- 靈敏度 (2.83 伏特/米): 93dB
- 頻率響應: 50Hz – 20kHz
- 阻抗: 3ohms

TS 參數

- BL (Tm): 3.533
- DCR (ohms): 2.34
- Mms (g): 22.973
- Sd (cm²): 237.79
- Cms (µm/N): 0.404
- Vas (l): 32.3563
- Fs (Hz): 52.2
- Qes: 1.413
- Qms: 13.661
- Qts: 1.281
- Crossover Point: 5kHz



HARMAN International Industries,
Incorporated
8500 Balboa Boulevard, Northridge,
CA 91329 USA

© 2018 HARMAN International
Industries, Incorporated.

保留一切權利。

JBL 是 HARMAN International Industries, Incorporated 在美國與/或
其他國家的註冊商標。

功能、技術規格和外觀如有變更,恕不另行通知。